

KRÄMER GREBE

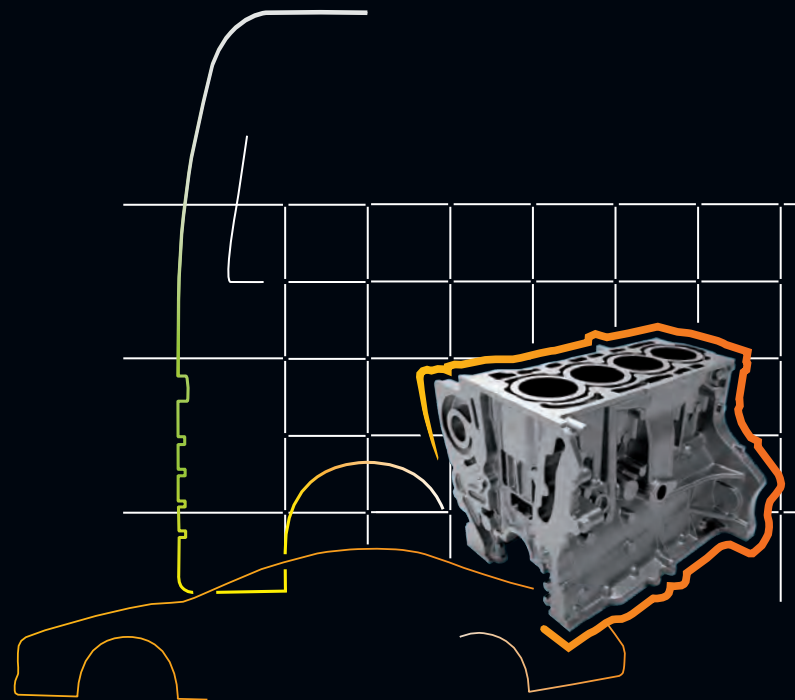

FORMING INNOVATIONS



IMPRESSIONS

FORMING INNOVATIONS



For many years, the international automotive industry and well-known foundry companies have valued the great innovative strength and the enormous creativity of the team. As a family company in our 4th generation, we are among the market leaders worldwide. We stand for 90 years of experience, passion, comprehensive know-how and reliability. The most modern technology and methods of management, communication and production ensure our optimally matched design and manufacturing concepts. At KRÄMER+GREBE, you will benefit with 100% expertise from a single source for custom-made tool concepts. This makes us flexible and innovative – always dedicated to the special requirements of our customers.

Anyone who has visions in casting
will form innovations together with us.

Yours, Katrin Grebe

A handwritten signature in blue ink that reads "Katrin Grebe". The signature is fluid and cursive.

President

FORMING IDEAS

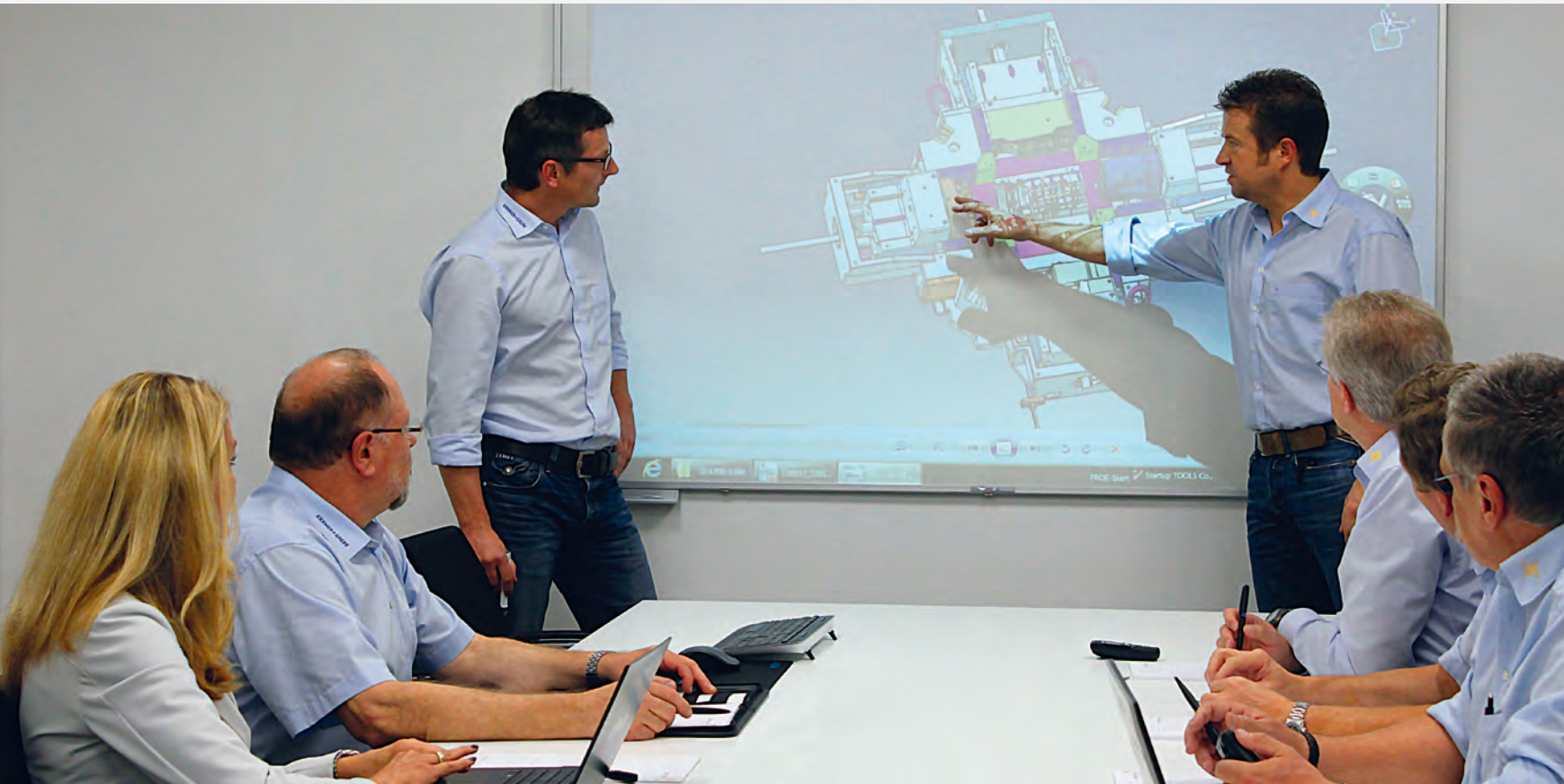

KRÄMER+GREBE is a specialist in molds and complete model and tooling equipment for complex and high-stress cast components. A team of outstanding tool- and patternmakers designs and produces a wide range of tools for light metal and gray iron castings. The business activity begins with comprehensive consulting services for specific solutions and goes through the design and development of all the requirements all the way up to the final production of foundry tooling for sand casting, permanent mold casting and high-pressure die casting.

FORMING TECHNOLOGY

THROUGH SIMULTANEOUS ENGINEERING

In close cooperation with our customers, we develop and manufacture tailor-made tooling equipment from steel, cast iron, aluminum and plastic for prototype and full-scale production.

The proven and successful basis for both design and manufacturing concepts, as well as for the process capability of the tools, is simultaneous engineering – a method that exploits synergies and saves time.

In combination with modern machinery, certified quality management and exemplary service, KRÄMER+GREBE is the essential partner for your success.

The service portfolio includes:

- Consulting, development and design
- Prototype tooling
 - Rapid prototyping,
 - Hand stamping core boxes,
 - Production quality and standardized concept solutions
- Core Box Tooling for all processes
 - Cold Box-, Hot Box-, Croning- and
 - Warm Box Tooling for inorganic cores
- Complete tooling solutions for the Core Package System (CPS) and the Green Sand Molding Procedure
- Patterns for molding facilities
- Permanent molds for various casting processes
 - Gravity molds
 - Low-pressure molds
- Molds for tilt casting
 - Molds for the rotacast process and
 - Molds for Counter-Pressure Casting (CPC)
- High-Pressure Dies up to 80 tons
- Special machines, handling devices and equipment
- Comprehensive service for modification, repair, maintenance and process start-up



Our varied tasks include technologically challenging tooling for the casting of items such as engine blocks, cylinder heads and cast components for chassis, drive and safety equipment, and up through complex tool projects. From the initial design to the finished product, we support all phases of the project execution. This guarantees the highest precision, the necessary flexibility, the absolute process reliability along with perfect execution. Tight dimensional tolerances, high surface finishes, thermal and mechanical stability as well as complex geometries and component structures are the outstanding quality features.

The KRÄMER+GREBE team provides a valuable contribution and creates reliability in production.

FORMING KNOW-HOW

THROUGH GOOD PERSONNEL WORK

Consistent knowledge management, innovative design concepts, and computer-controlled processes are important constants for lasting success.

This requires people who think through a task and devote themselves passionately to developing the best technical solutions: That is what our expert employees offer. Their skillfulness makes our extremely high-quality and modifiable tooling and pattern equipment what it is: a guarantee of the highest possible quality and a decisive competitive advantage. This is why we set such great store on responsible Human Resource Management. In our in-house training, apprentices are trained as skilled professionals – as technical patternmakers, technical product designers and toolmakers. There are also Bachelor and Masters' students who are supervised in obtaining their degrees in dual studies with a high practical content. Multiple state and national awards to trainees are evidence of the good personnel work at KRÄMER+GREBE.

FORMING FUTURE

THROUGH INVESTMENTS

We know the requirements of the present and are thinking ahead to the future. This only succeeds because we take development and progress as our maxim and can draw from a large pool of experience. The trust of our customers is our driving force. For that reason, we invest regularly in cutting-edge technologies and methods for engineering, manufacturing, planning and communication. Top quality is always one of the most important goals at KRÄMER+GREBE. All of our machines conform to the highest requirements and to the latest state of advanced manufacturing technology. They are operated by well-trained professionals who know exactly how to achieve peak performance.



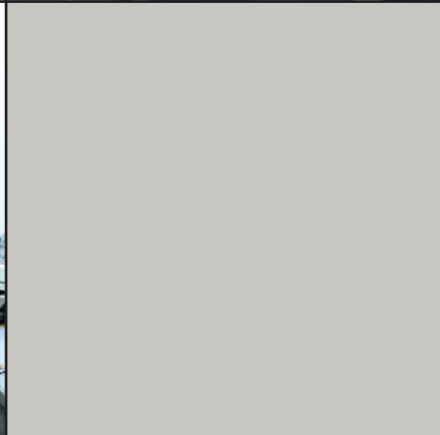
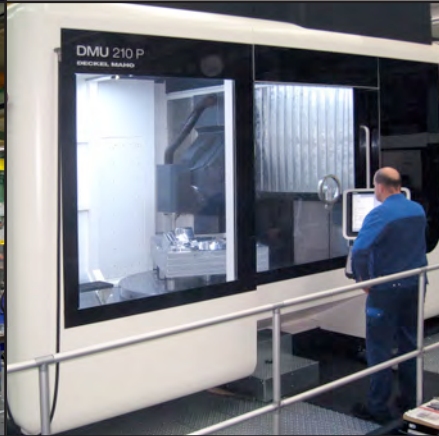
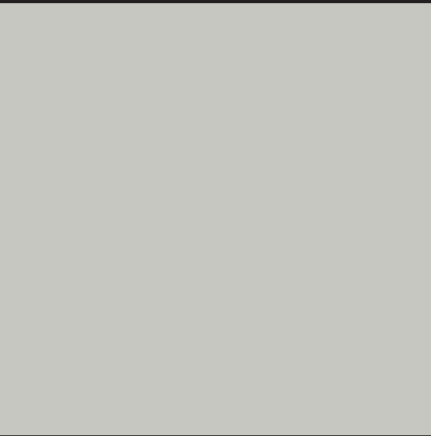
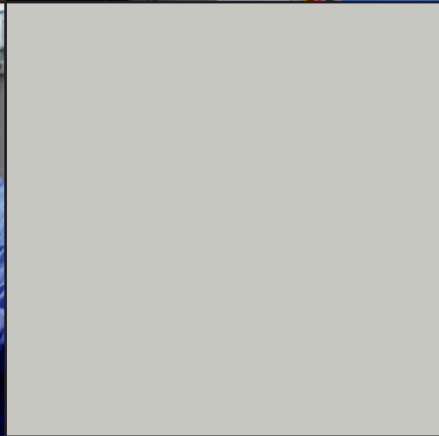
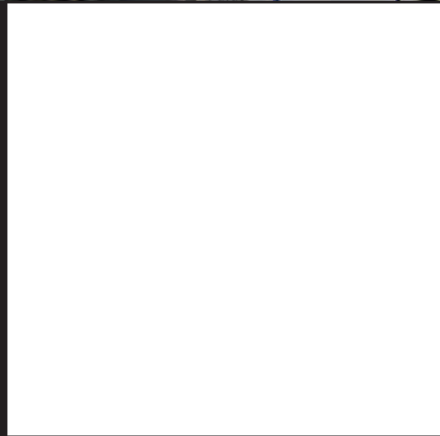



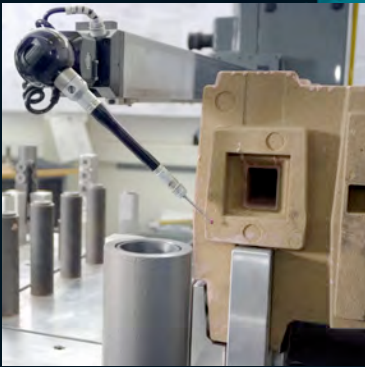
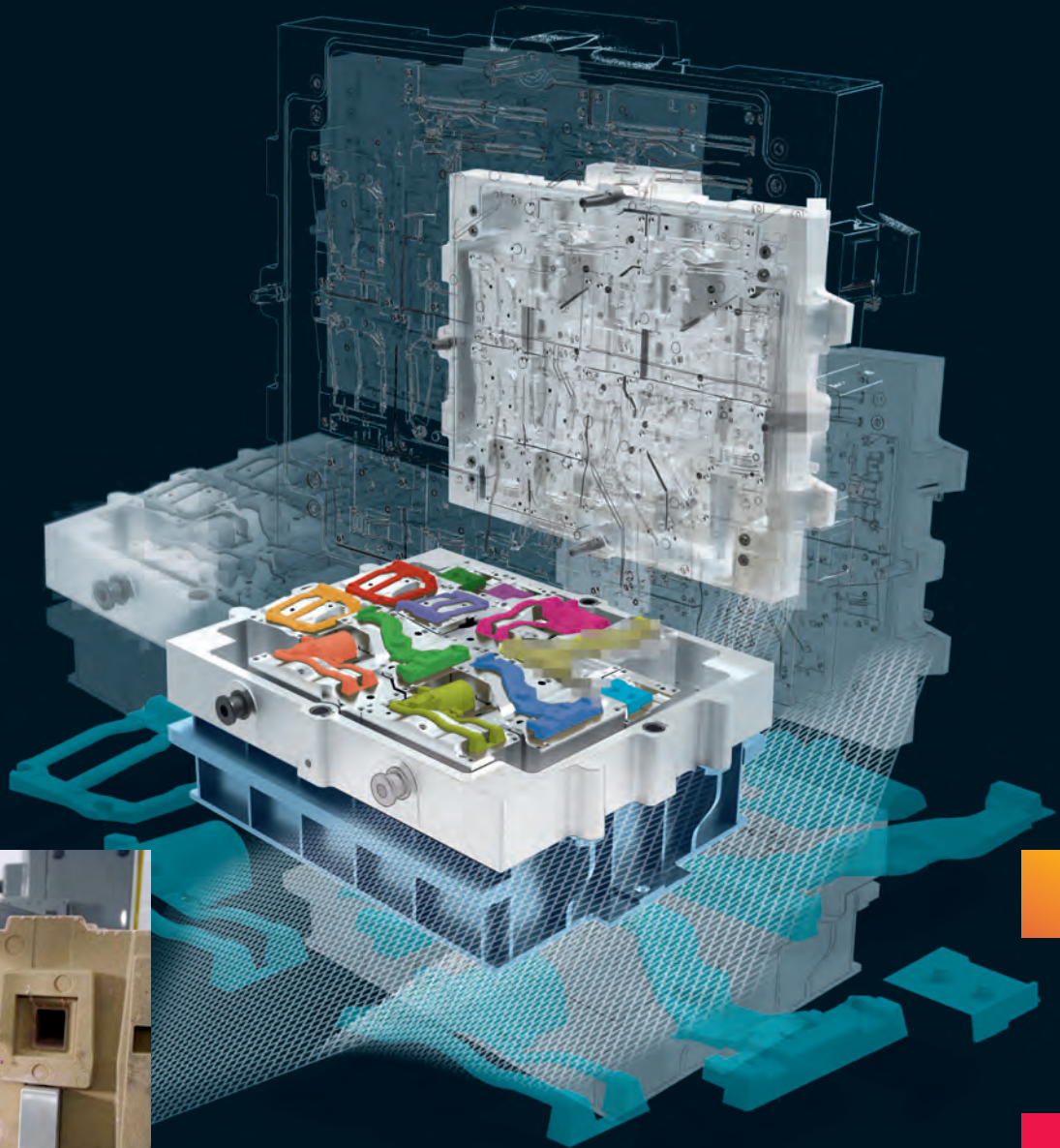

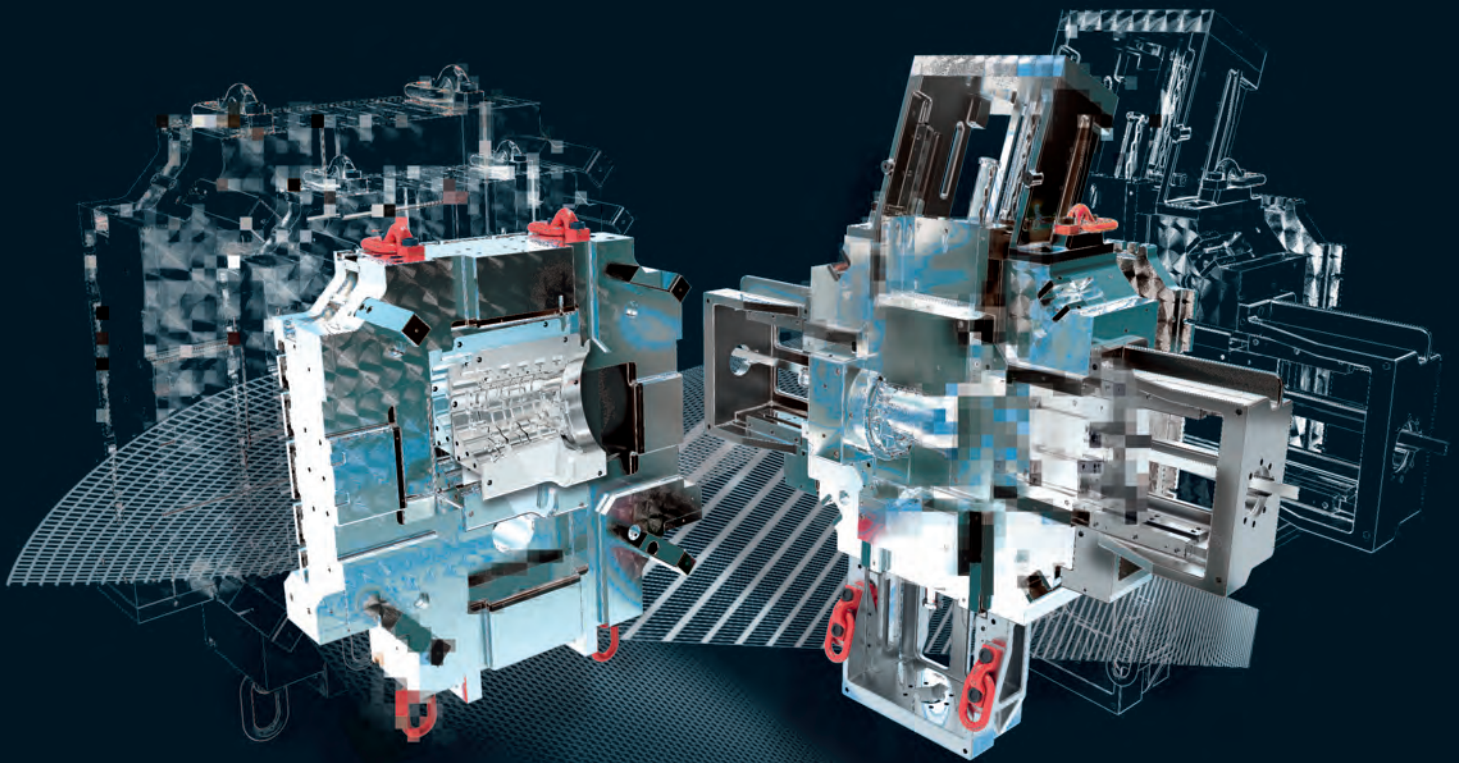

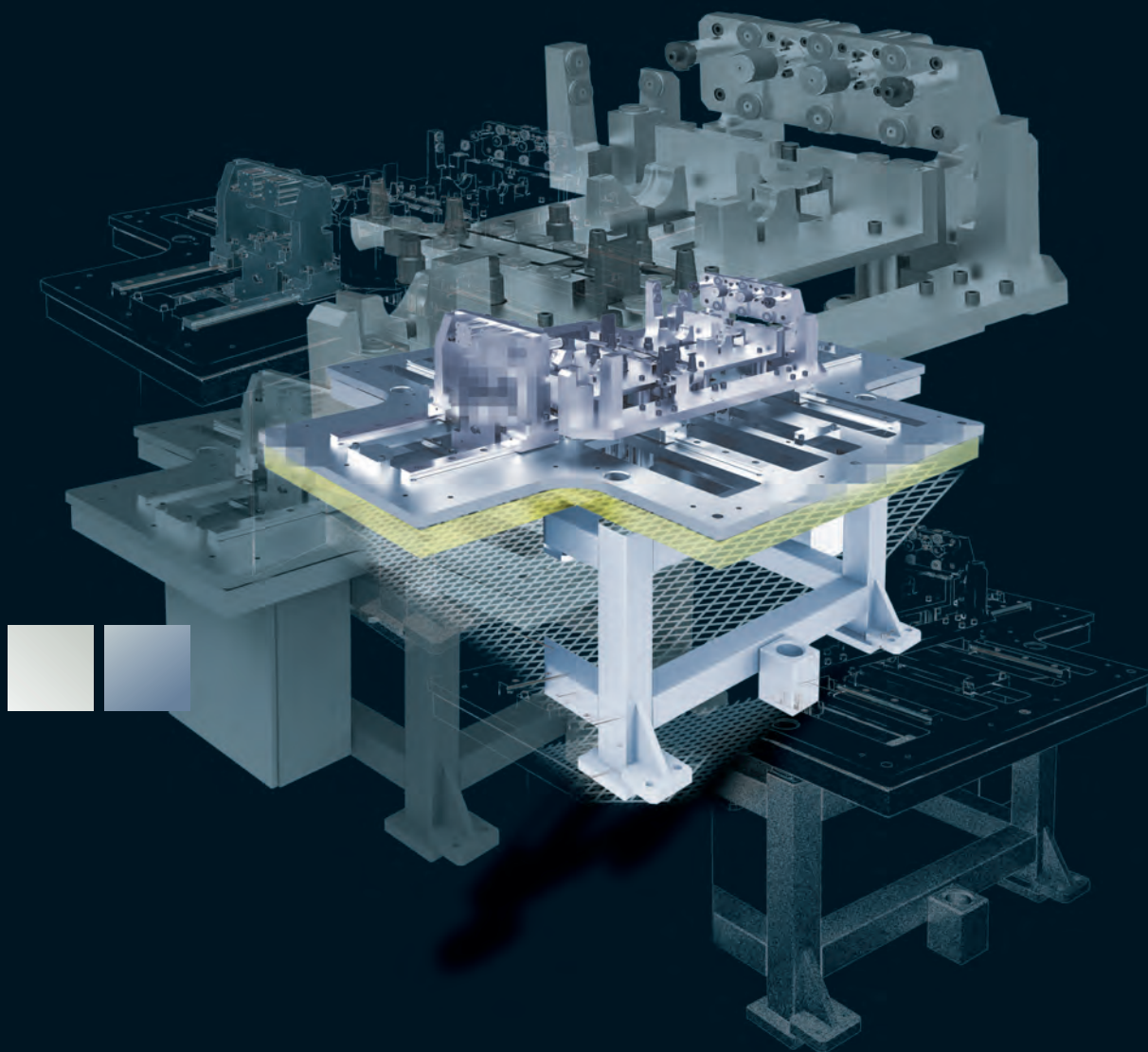

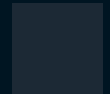
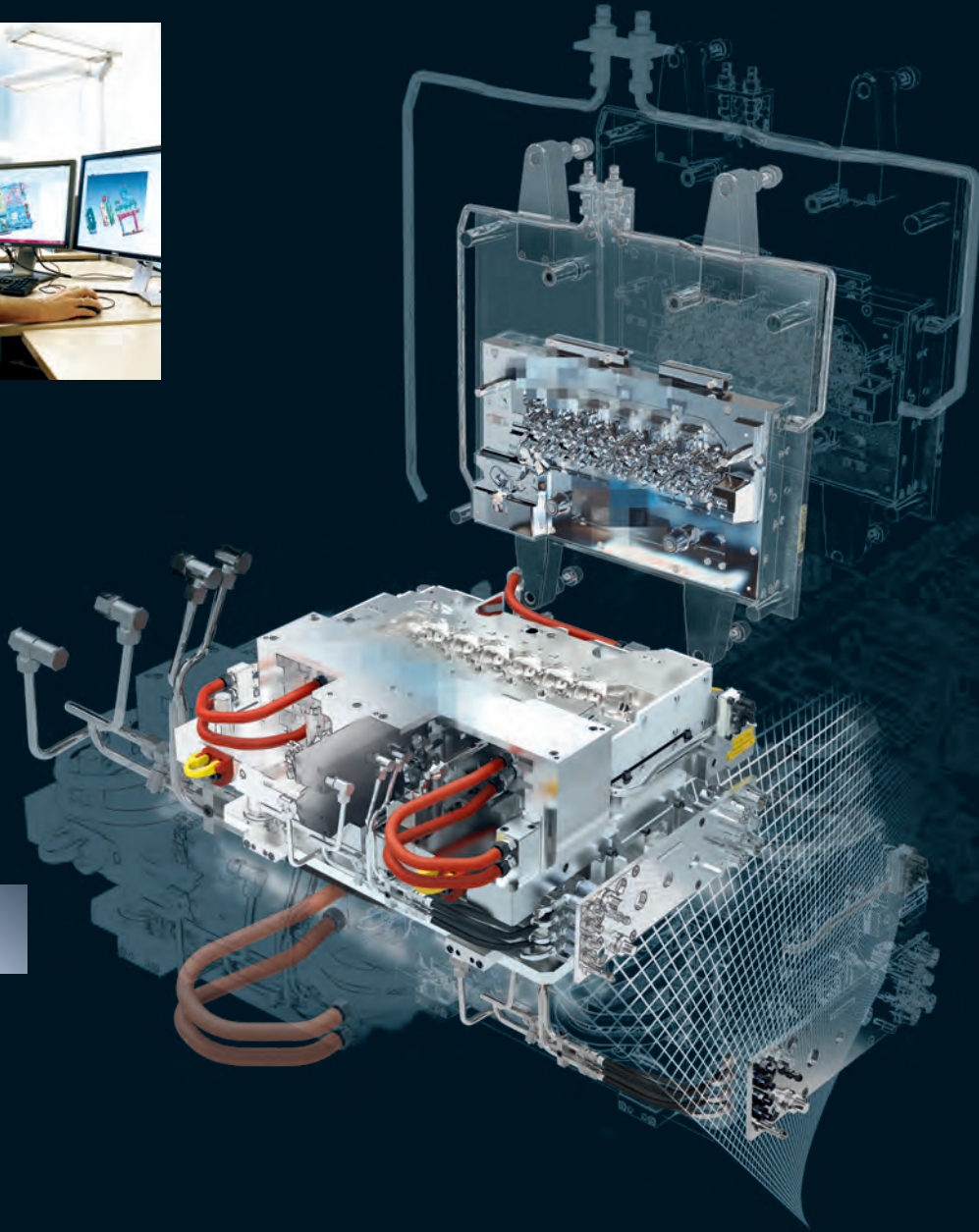

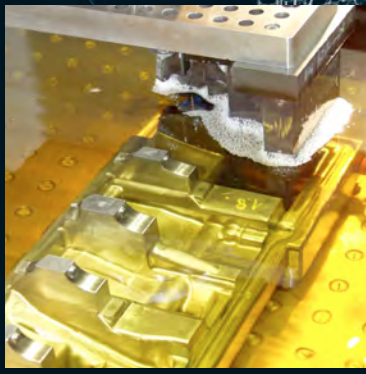
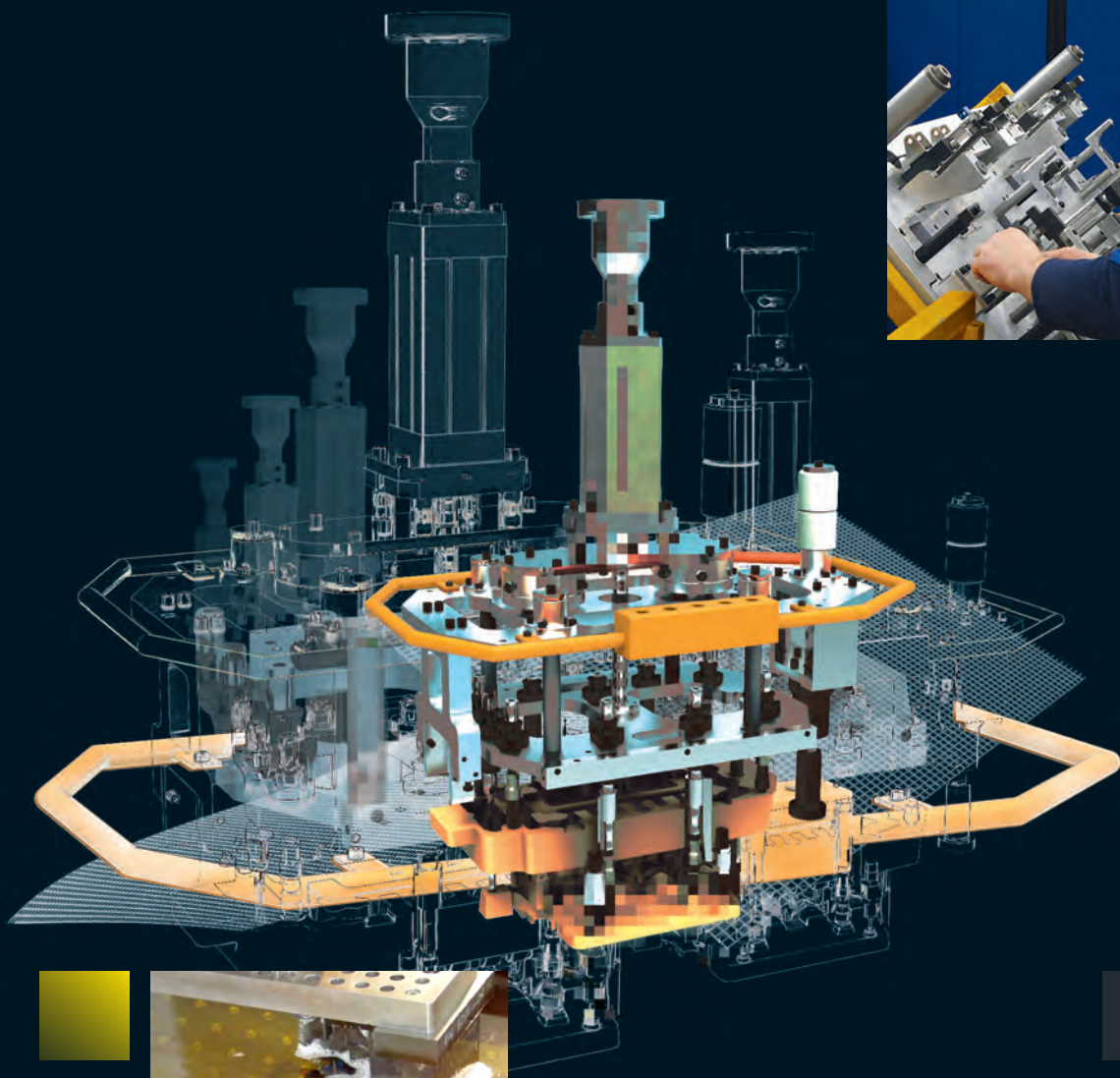

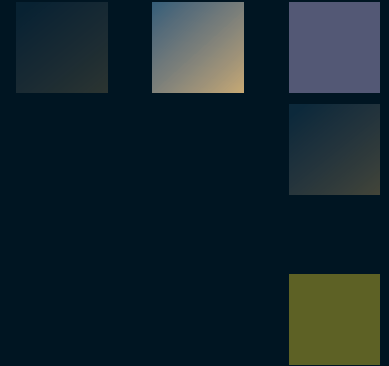
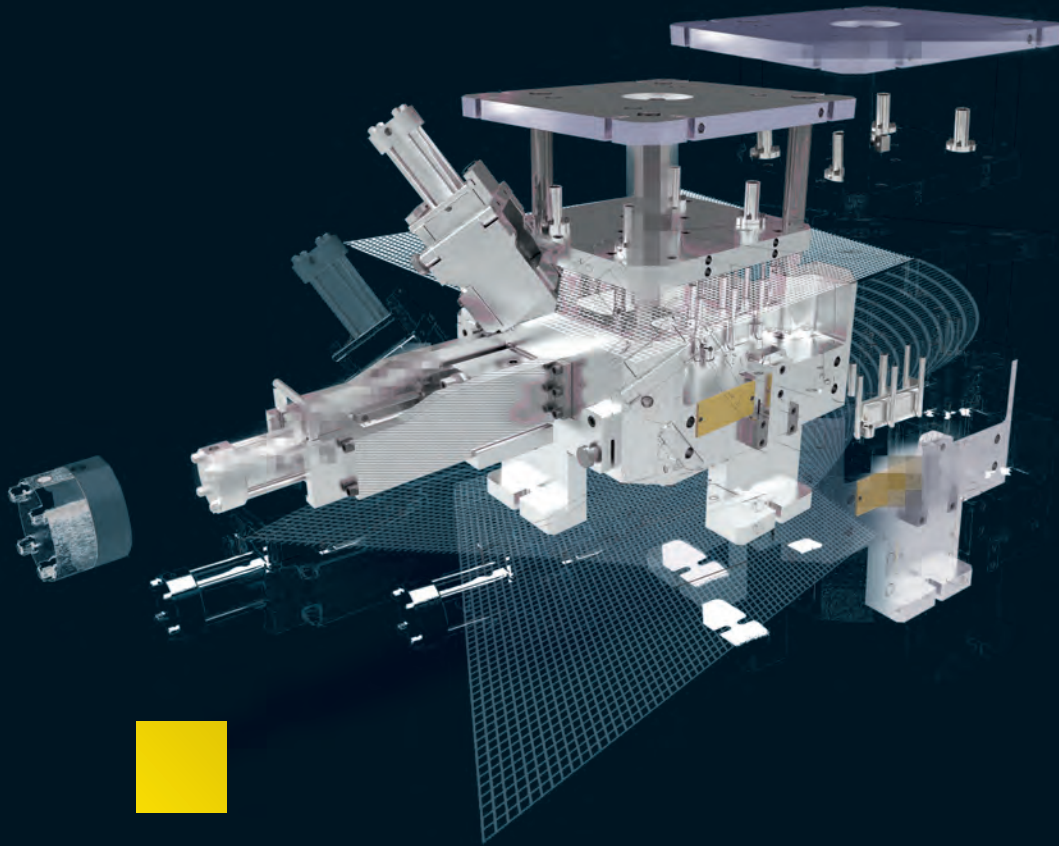

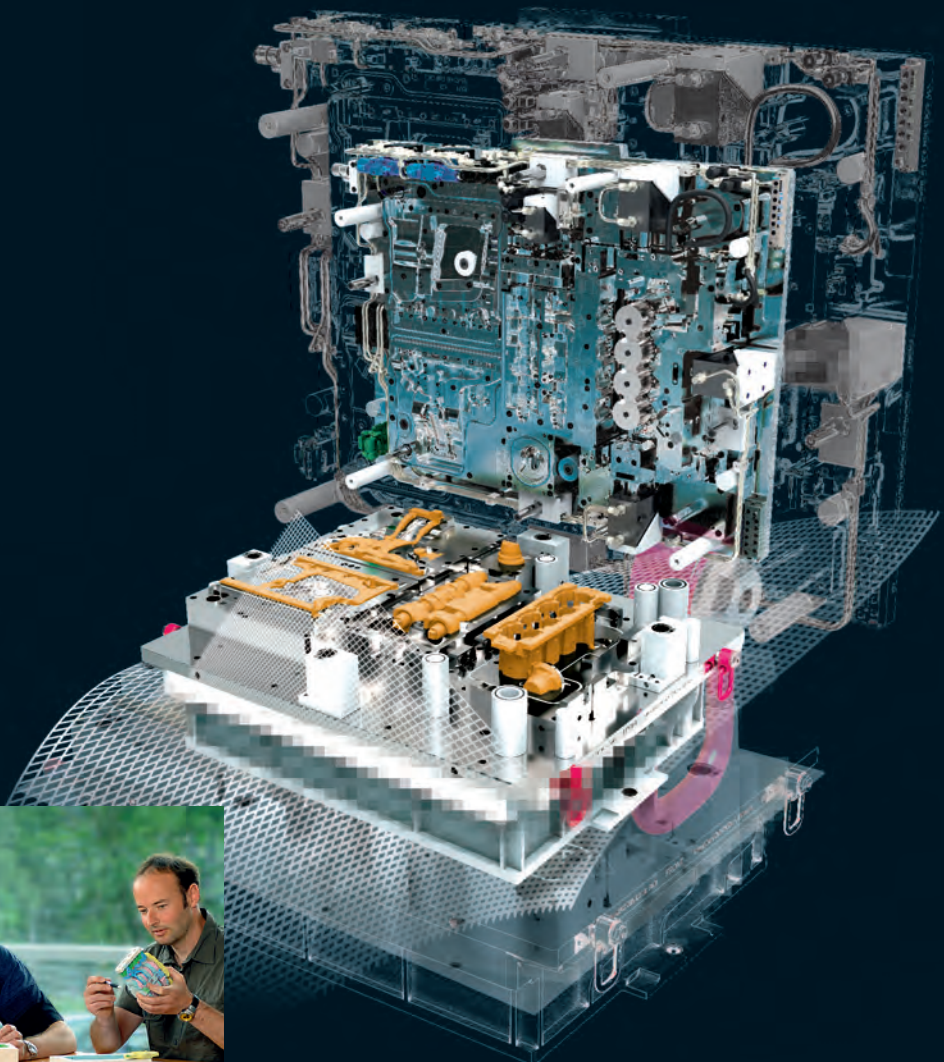

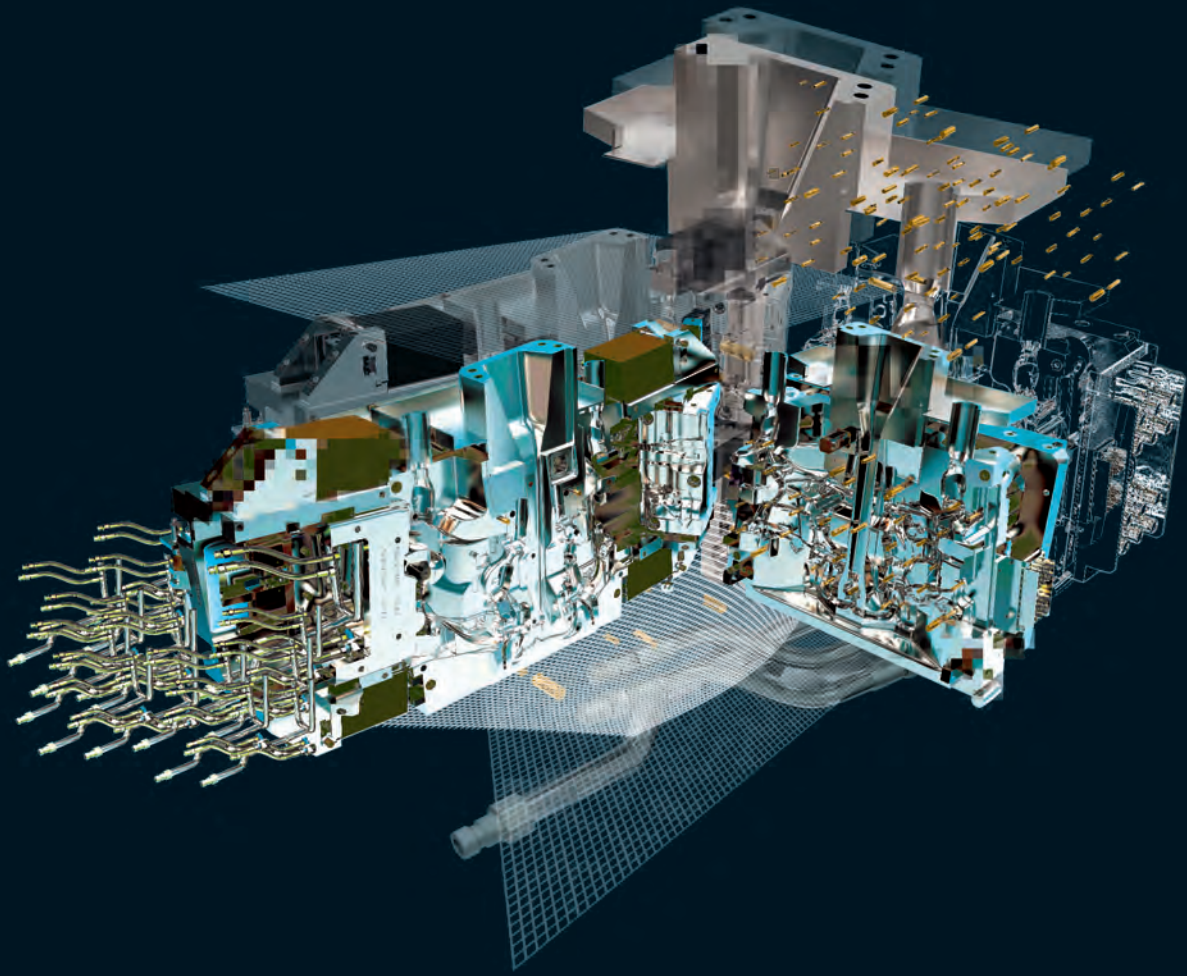
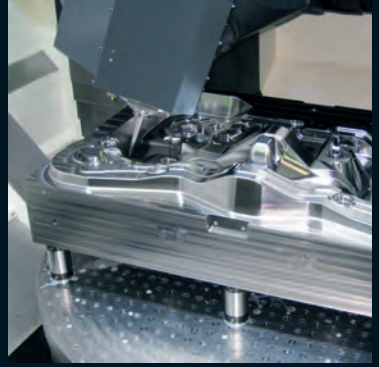

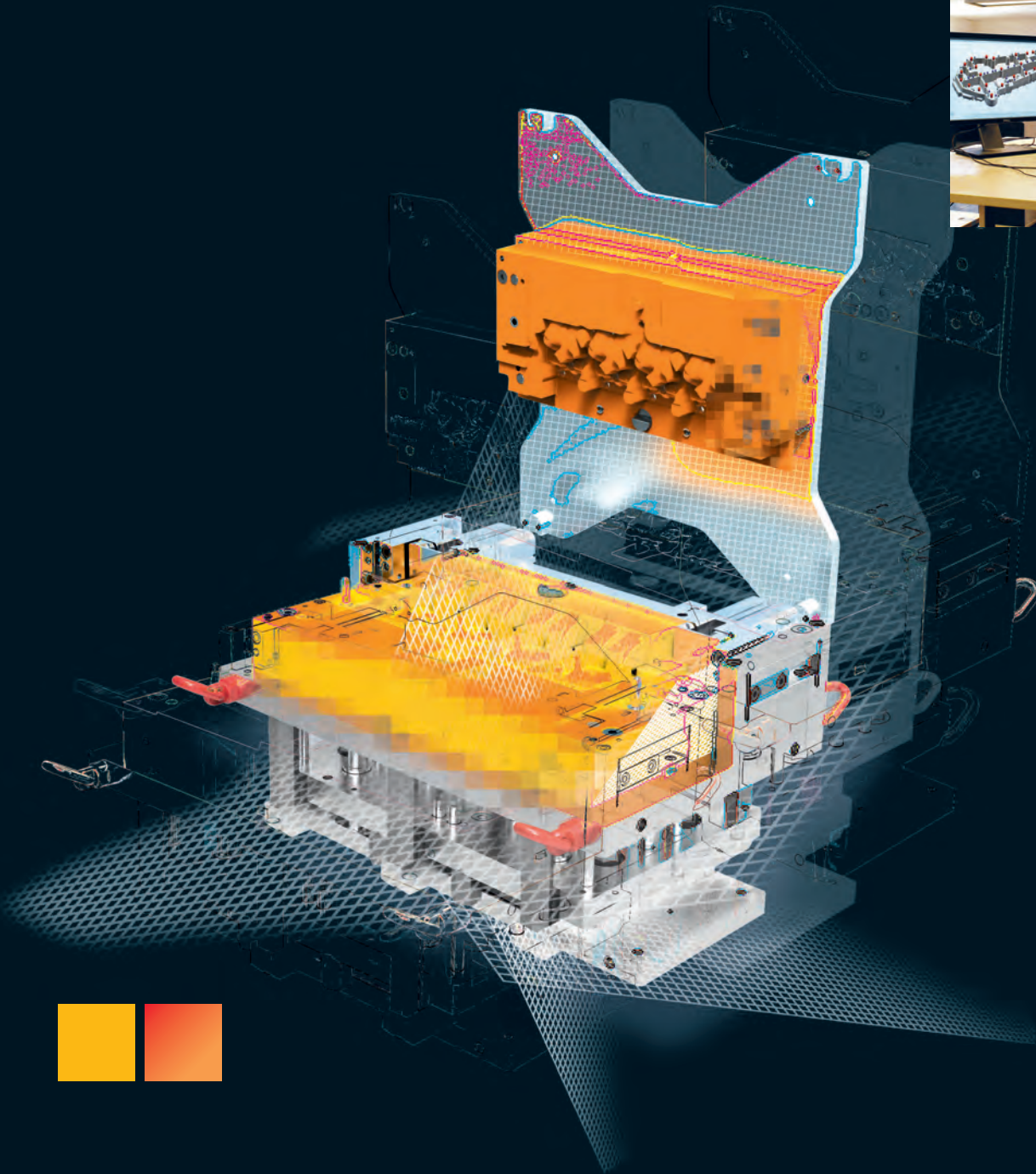

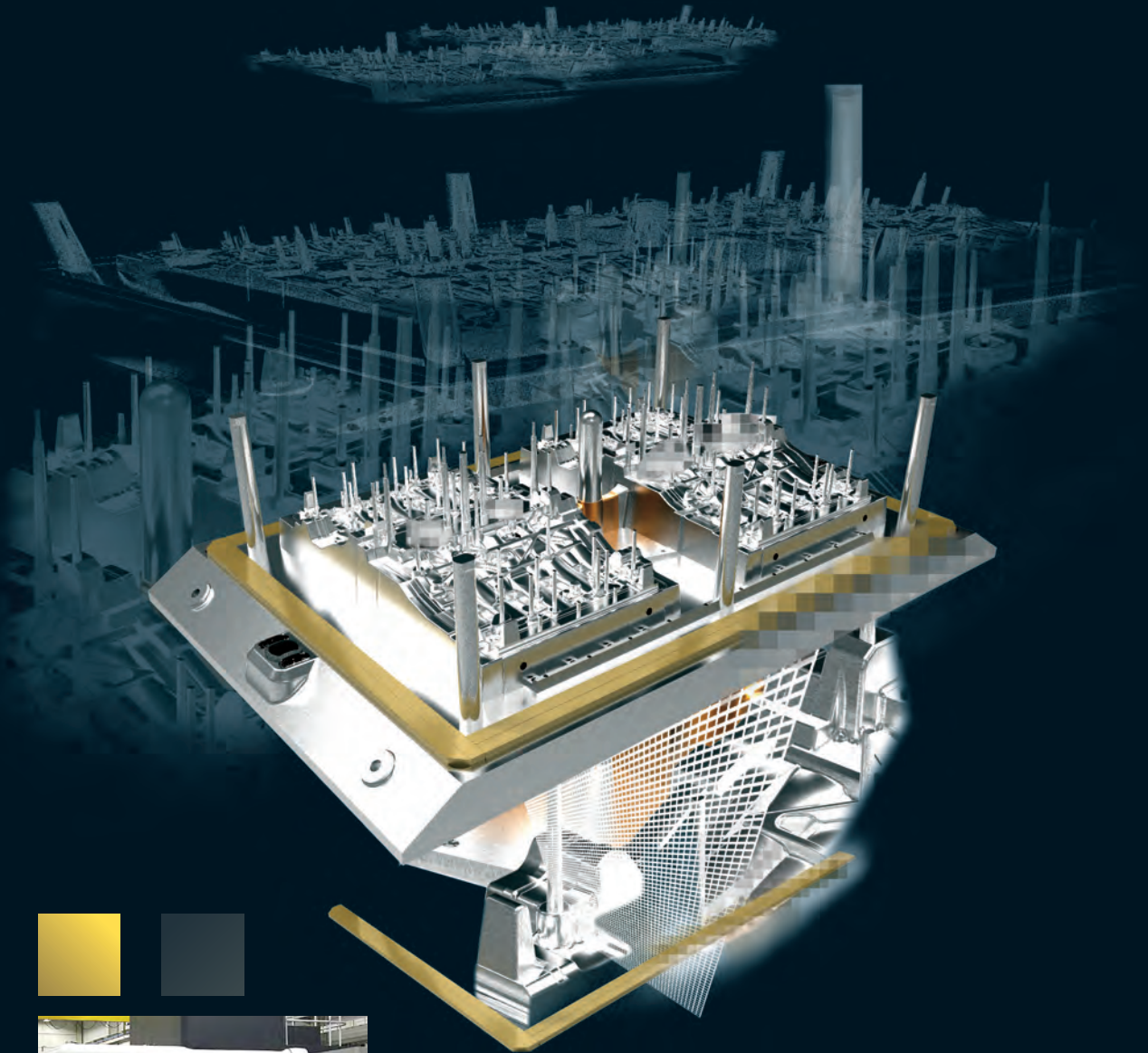

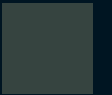
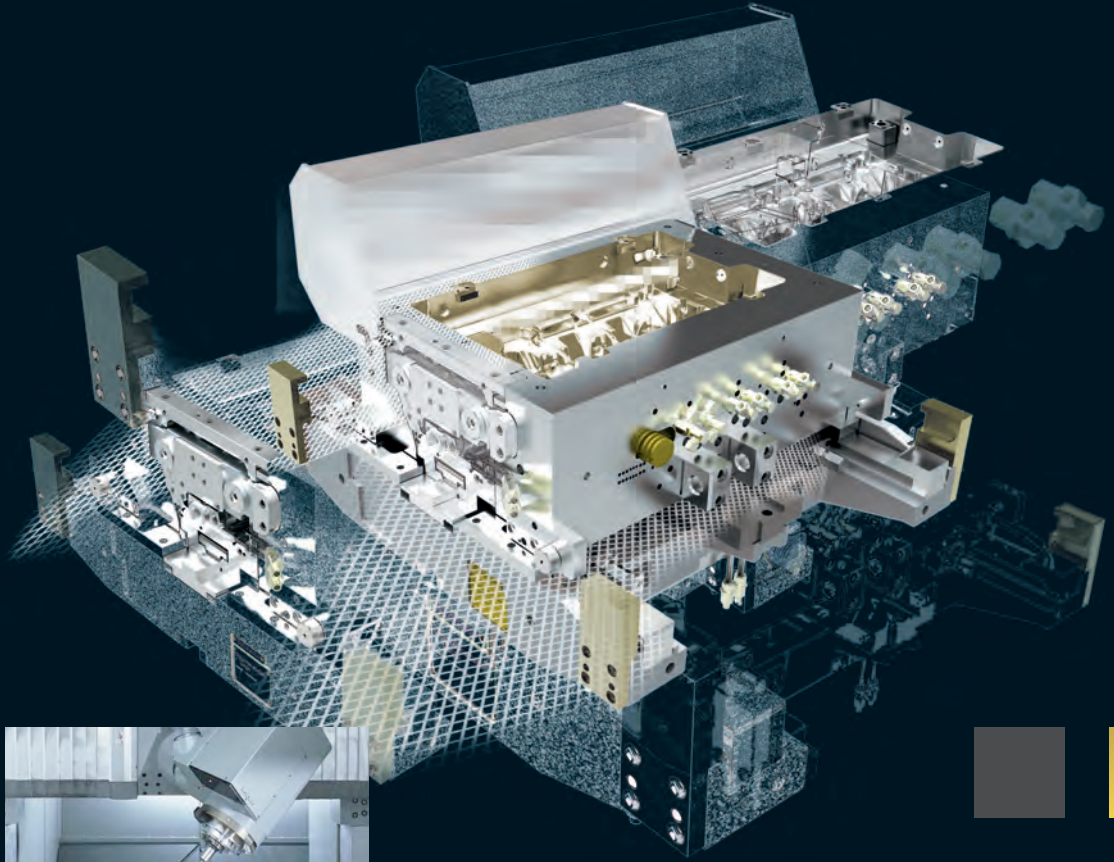

KRÄMER+GREBE

STANDS FOR THE FOLLOWING:



- Individual and complete tooling solutions for foundries
- Tooling equipment from the prototype stage to high-volume production
- Worldwide supply and support of process start-ups
- 90 years of experience in pattern and tooling construction
- Short development and throughput times
- Innovation strength and flexibility: everything from a single source
- Optimum Human Resource Management
- An expert and dedicated team
- Expertise even in the latest technologies
- Simultaneous engineering
- CAD, CAE and CAM technology
- Modern tools for project and process planning
- State-of-the-art manufacturing technology
- Over 30 complete machining centers, also with simultaneous milling
- High-Pressure die cast tooling with weights up to 80 metric tons
- The latest techniques and standards in quality assurance
- Extensive capacities
- Perfect dialog with our customers
- Trouble-free order processing and first-class service
- Certified quality and environmental management
- Sustainability and long-term company strategy
- Central location in Germany

FEEDBACKS

JEAN MARC SÉGAUD

Head of Innovation Management and Advanced Development,
BMW light metal foundry

"A general shift away from an organic to an inorganic binder system means that all new products have been successively developed with the new core technology. Product development is linked to the high demand for flexibility and efficient change management during the product development process.

Absolute reliability of the delivery quality and compliance with deadlines is also essential. Since the conversion is not backward-compatible, there is no "back-up" solution – it has to work.

With Krämer+Grebe, we are acutely aware of that fact. We work really well together. Quality, adherence to deadlines, and an acceptable cost structure – these factors are important. Of course, a high level of service also impacts the cost structure. Ms. Grebe and her team have found a golden middle way to address this issue."

KLAUS LEVASIER

Head of Model Construction, Mercedes-Benz

"The further development of tool concepts is extremely important. We benefit from the experience of suppliers and service providers whose knowledge makes them important sparring partners in discussions and meetings. In these lively discussions, we clarify many aspects and receive additional suggestions which assist us in our work. We have been very effective in this respect during the past few years. Not only are technical solutions required – it is also a matter of selecting the right materials. Do we use plastic? Or would steel be better? What do we know from experience? The team of Krämer+Grebe offers expertise in a wide range of areas."

MATTHIAS BARANZKE

Product Design Manager, Nemak Dillingen

"The whole concept of Krämer+Grebe fits. Ms. Grebe and her team have realized that new technologies and services are important building blocks. They consistently implement this knowledge. In particular, the simulation, the video conference system and the on-site personnel meet our requirements, for example, in the area of design."

WIM GÖRTZ

Head of Product Development, Eisenwerk Brühl

"The company stands out for its delivery reliability, the quality of its products and the development expertise of the team. In special situations, Krämer+Grebe reacts quickly, meeting customer requirements with great flexibility. In addition, the employees are always ready and willing to assist – the customer always comes first.

Our collaboration has had strong continuity. I have been at Eisenwerk Brühl for 18 years now and my contacts at Krämer+Grebe have changed little during that time. Krämer+Grebe is a very reliable supplier, both in good as well as in difficult economic times. We also appreciate the high degree of fairness and the integrity of the employees. In addition, the continuous communications throughout the entire process chain represent a major competitive advantage."

HERBERT JUNK

Senior Engineer, Neue Halberg-Guss

"The people at Halberg and Krämer+Grebe understand each other very well – personally and also in terms of work. Krämer+Grebe has very, very creative people who have a great capability for learning. They have incredibly wide experience and can quickly implement our requirements.

Of course we also benefit from the wide networking of the entire company, which makes Krämer+Grebe a valuable business partner. The employees are all trained to an outstanding degree. The company is at the forefront of technology, knows the competition and has all the relevant tools. Compared to its competition, everything is right – from speed and reliability all the way to the cost."

FORMING TOGETHER

We are gladly at your disposal, whenever you are looking for complex foundry tools, with high quality and tolerance requirements, with design and concept for fast cycle times and low maintenance costs. You will be supplied reliably, at the right time, looked after by a team with natural service capability, from development to the process start-up and through to maintenance.

KRÄMER + GREBE GmbH & Co. KG

Modell- und Werkzeugbau
Ludwig-Grebe-Str. 5
D-35216 Biedenkopf-Wallau

Phone: +49 6461 8008-0
Fax: +49 6461 8008-60
www.kraemer-grebe.de
info@kraemer-grebe.de

